

Detecting Peering Infrastructure Outages

GORE/ESNOG20, Madrid

Vasileios Giotsas ^{†*}, Christoph Dietzel ^{†§}, Georgios Smaragdakis^{††},
Anja Feldmann [†], Arthur Berger ^{†‡}, Emile Aben [#]

Presented by Matthias Wichtlhuber [§]

Peering Infrastructures are critical part of the interconnection ecosystem

Internet Exchange Points (IXPs) switching fabric for layer-2 bilateral and multilateral peering.

- Largest IXPs support > 100 K of peerings, ~6 Tbps peak traffic
- Typical SLA 99.99% (~52 min. downtime/year)¹

Carrier-neutral **colocation facilities** (CFs) infrastructure for physical colocation and cross-connect interconnections (PNI).

- Largest facilities support > 170 K of interconnections
- Typical SLA 99.999% (~5 min. downtime/year)²

¹ <https://ams-ix.net/services-pricing/service-level-agreement> ² <http://www.telehouse.net/london-colocation/>

Outages in peering infrastructures can severely disrupt critical services and applications

DOWNTIME WOES —
BT, other ISPs hit by second major Internet outage—power failure blamed

After Telecity power outage, it seems Telehouse has had problems of its own.

KELLY FIVEASH · 21/7/2016, 03:05



BT broadband users hit by second UK-wide outage in two days

Power supply issues at Docklands data center behind loss of internet access for more than 1 million broadband users

Caroline Donnelly
 Datacentre Editor
 21 Jul 2016 9:50

Equinix cooling outage leads to flight delays in Australia

13 November 2012 | By Penny Jones

A "short interruption to utility power supply" at an Equinix data center in Sydney caused up to three hour delays for thousands of passengers flying with three major airlines from Australian airports over the weekend.

DOWNTIME
Equinix Outage Means Downtime for Zoho

BY RICH MILLER ON JANUARY 20, 2012 [ADD YOUR COMMENTS](#)

A power outage Friday morning in an **Equinix** data center in California caused problems for a number of customers, most notably Zoho, which experienced hours of downtime for several of its web-based office applications. Equinix [acknowledged](#) the incident, but did not provide details on the cause of the outage at its SV4 facility in Silicon Valley.

TECHNOLOGY TOP STORIES
OUTAGE AT AMSTERDAM INTERNET HUB AFFECTS MUCH OF NETHERLANDS

By Janene Pieters on May 13, 2015 - 13:11

With additional reporting by Zack Newmark.

A technical fault at the internet hub AMS-IX in Amsterdam caused online problems in several places in the Netherlands for about an hour Wednesday afternoon. The internet hub, one of the most used internet exchanges in the world, announced they resolved the problem shortly after 1:30 p.m.

THE REGISTRY
 Biting the hand that feeds IT

SECURITY TRANSFORMATION DEVOPS BUSINESS PERSONAL TECH

Telecity London data centre outage borks VoIP, websites, AWS...

LINX reports sudden sharp traffic drop, Amazon Direct Connect goes TITSUP

Outages in peering infrastructures can severely disrupt critical services and applications

DOWNTIME WOES —
BT, other ISPs hit by second major Internet outage—power failure blamed
 After Telecity power outage, it seems Telehouse has had problems of its own.
KELLY FIVEASH · 21/7/2016, 03:05

BT broadband users hit by second UK-wide outage in two days

Equinix cooling outage leads to flight delays in

Outage detection crucial to improve **situational awareness, risk assessment** and **transparency.**

TECHNOLOGY TOP STORIES
OUTAGE AT AMSTERDAM INTERNET HUB AFFECTS MUCH OF NETHERLANDS
 By Janene Pieters on May 13, 2015 - 13:11
 With additional reporting by Zack Newmark.
 A technical fault at the internet hub AMS-IX in Amsterdam caused online problems in several places in the Netherlands for about an hour Wednesday afternoon. The internet hub, one of the most used internet exchanges in the world, announced they resolved the problem shortly after 1:30 p.m.

California caused problems for a number of customers, most notably Zoho, which experienced hours of downtime for several of its web-based office applications. Equinix [acknowledged](#) the incident, but did not provide details on cause of the outage at its SV4 facility in Silicon Valley.

ITC REGISTER
Biting the hand that feeds IT
 SECURITY TRANSFORMATION DEVOPS BUSINESS PERSONAL TECH

Telecity London data centre outage borks VoIP, websites, AWS...
 LINX reports sudden sharp traffic drop, Amazon Direct Connect goes TITSUP

Current practice: "Is anyone else having issues?"

[outages] Power problems at the Westin in SEA?

Sean Crandall [sean at megapath.com](mailto:sean@megapath.com)
Wed Feb 23 17:58:06 EST 2011

- Previous message: [\[outages\] Phonebooth.com Service](#)
- Next message: [\[outages\] Power problems at the Westin](#)
- Messages sorted by: [\[date \]](#) [\[thread \]](#) [\[subject \]](#) [\[author \]](#)

Hi everyone...

We appear to be having power problems in the Westin in Seattle and have heard reports of other colo providers having power issues which implies it is a greater building problem.

[Is anyone else having power issues in the Westin?](#)

[outages] So what is broken

Michael Peterman [Michael at seus4it.com](mailto:Michael@seus4it.com)
Tue Aug 12 14:21:09 EDT 2014

- Previous message: [\[outages\] Major outages today, not much info at this time](#)
- Next message: [\[outages\] So what is broken](#)
- Messages sorted by: [\[date \]](#) [\[thread \]](#) [\[subject \]](#) [\[author \]](#)

So is this issue all related to a fiber cut or a [DC/Peering point](#) having issues?

<http://www.thewhir.com/web-hosting-news/liquidweb-among-companies-affected-major-outage-across-us-network-providers>

Michael Peterman

[outages] Telehouse North - Major Problems

Phil Lavin [phil.lavin at cloudcall.com](mailto:phil.lavin@cloudcall.com)
Thu Jul 21 03:48:18 EDT 2016

- Previous message (by thread): [\[outages\] AT&T outage in Texas?](#)
- Next message (by thread): [\[outages\] Telehouse North - Major Problems](#)
- Messages sorted by: [\[date \]](#) [\[thread \]](#) [\[subject \]](#) [\[author \]](#)

We've just had 3 links drop simultaneously to (different) equipment in Telehouse North.

Fibre link to Vodafone - port is down
BGP peering to GTT is dropped
Copper link to BT - port is down

[Anyone else seeing anything?](#) We spoke to BT and they have confirmed a "major national problem".

- ASes try to crowd-source the detection and localization of outages.
- Inadequate transparency/responsiveness from infrastructure operators.

Current practice: “Is anyone else having issues?”

[outages] Power problems at the Westin in SEA?

[outages] So what is broken

[outages] Telehouse North -

Current practice is likely **to not provide a representative view of outage situation.**

Is anyone else having power issues in the Westin?

[affected-major-outage-across-us-network-providers](#)

We've just had 3 links drop simultaneously to (different) equipment in Telehouse North.

Fibre link to Vodafone - port is down
BGP peering to GTT is dropped
Copper link to BT - port is down

Michael Peterman

[Anyone else seeing anything?](#) We spoke to BT and they have confirmed a "major national problem".

- ASes try to crowd-source the detection and localization of outages.
- Inadequate transparency/responsiveness from infrastructure operators.

Our Research Goals

1. Outage detection:
 - *Timely*, at the *finest granularity* possible
2. Outage localization:
 - Distinguish *cascading effects* from outage *source*
3. Outage tracking:
 - Determine duration, shifts in routing paths, geographic spread

Main Challenge: Invisible Facilities

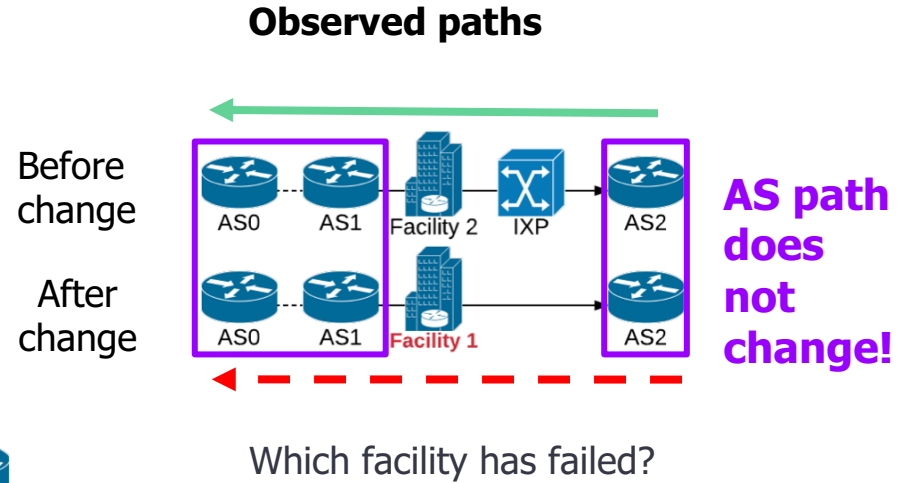
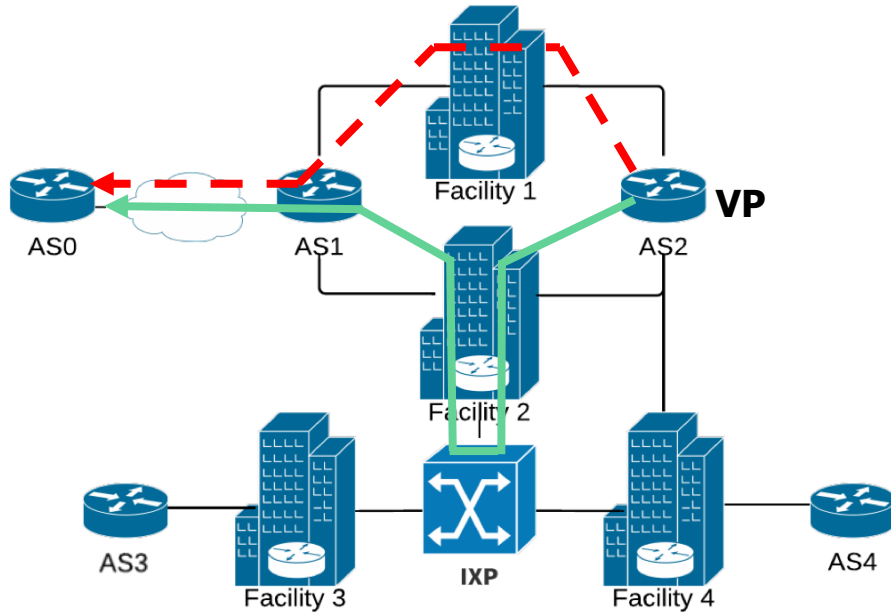

Main Idea: Utilizing BGP Communities

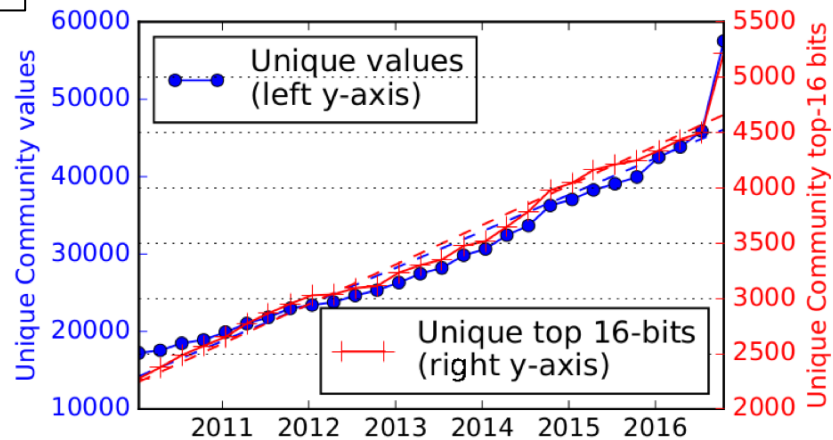
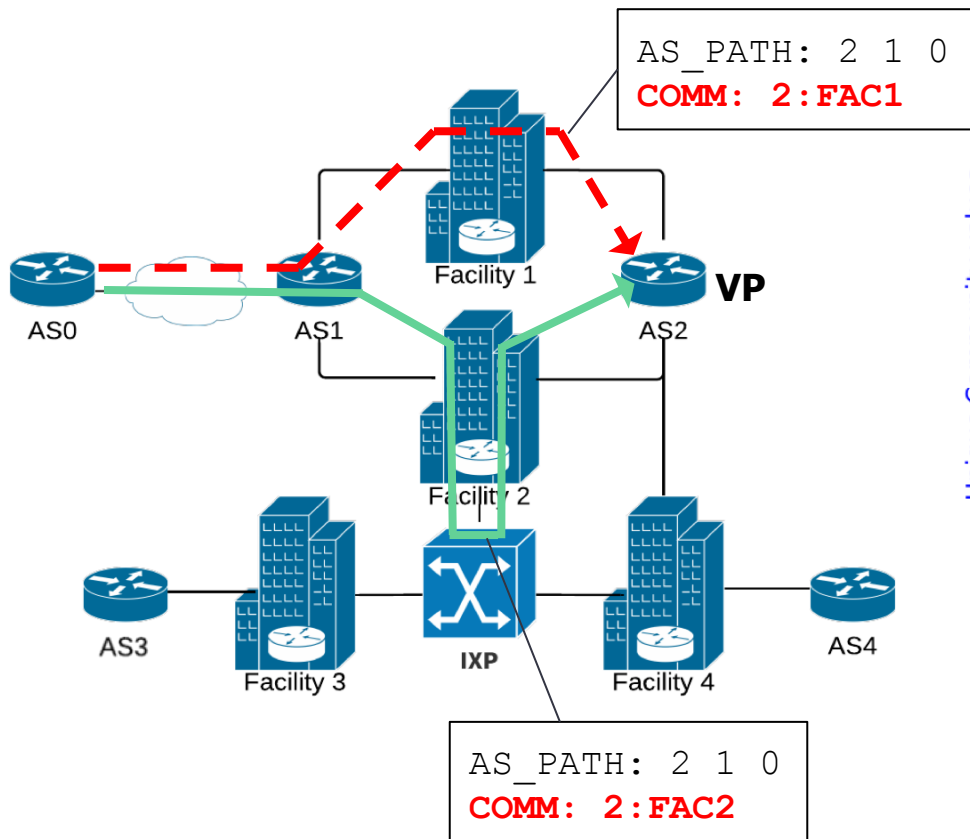

Community tag usage in BGP has increased by ~500% since 2010

Main Idea: Utilizing BGP Communities

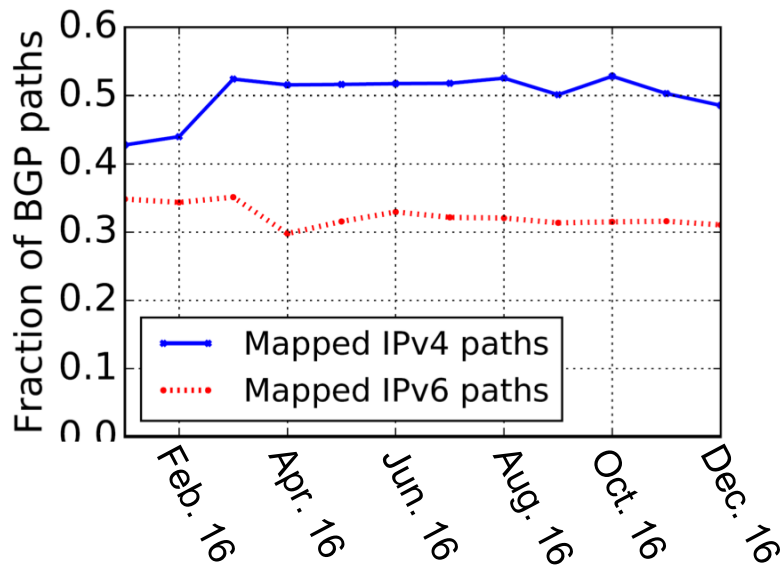

- Community usage is often public information (PeeringDB, operator websites, etc.) → map communities and facilities.
- ~50% of IPv4 and ~30% of IPv6 paths annotated with at least one Community in our dictionary.
- 24% of the facilities in PeeringDB, 98% of the facilities with at least 20 members.

Passive outage detection: Initialization

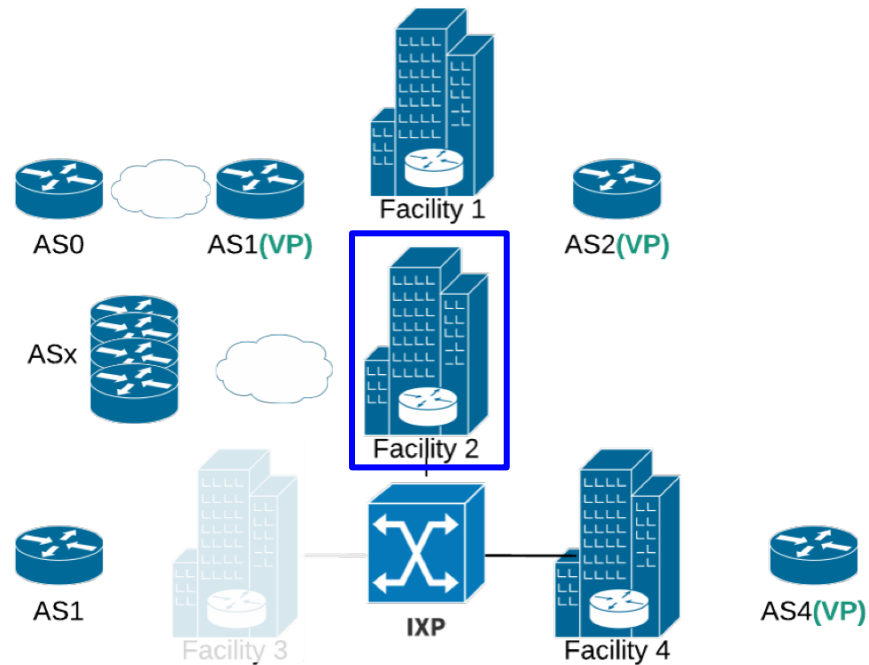
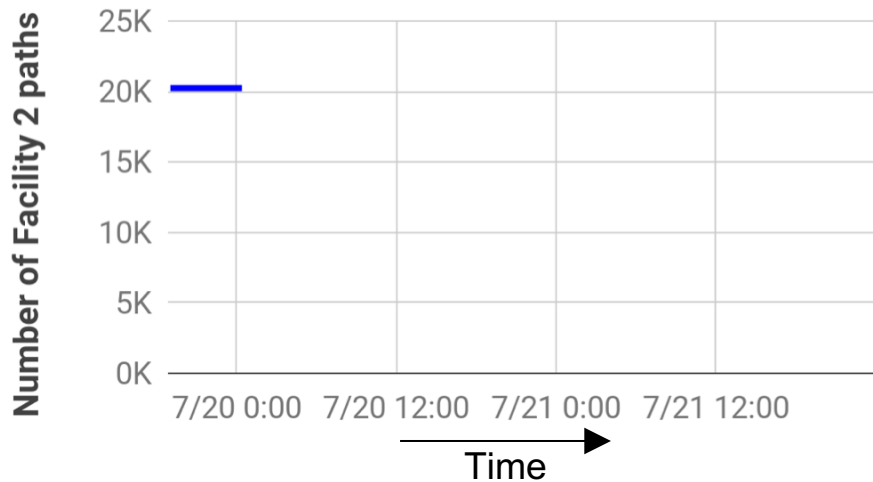

For each vantage point (VP) collect all the **stable** BGP routes tagged with the communities of the target facility (Facility 2)

Passive outage detection: Initialization

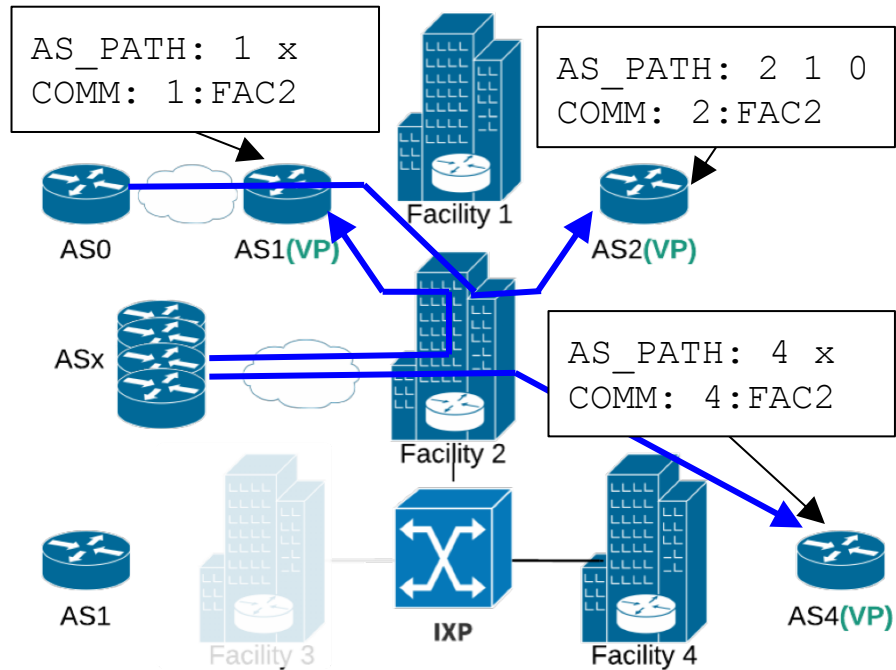
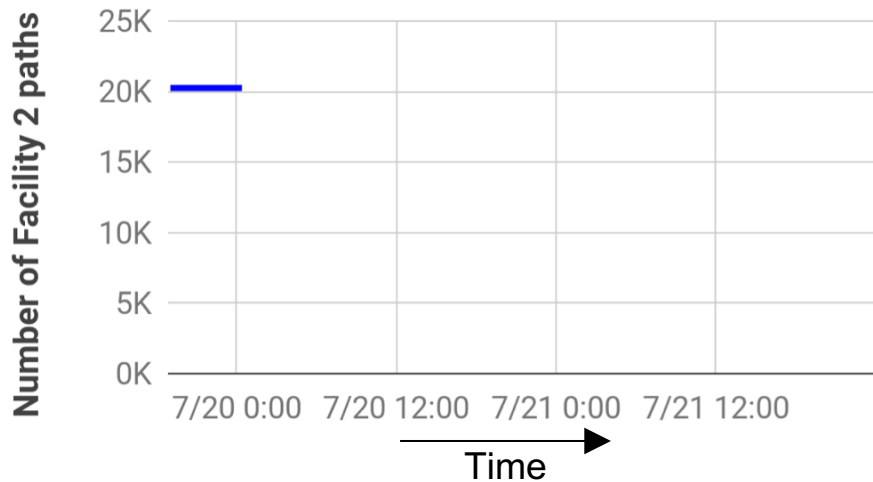

For each vantage point (VP) collect all the **stable** BGP routes tagged with the communities of the target facility (Facility 2)

Passive outage detection: **Monitoring**

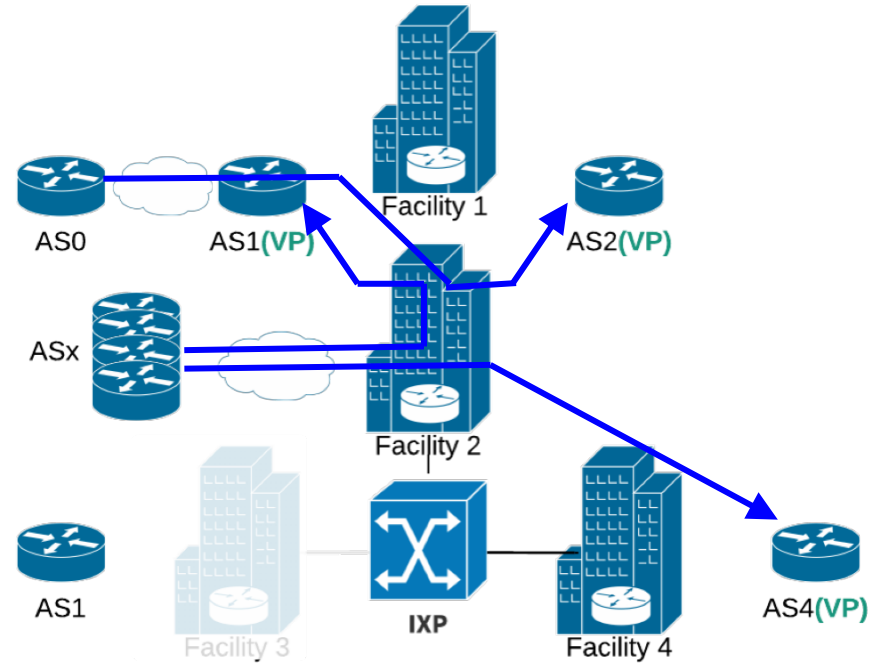
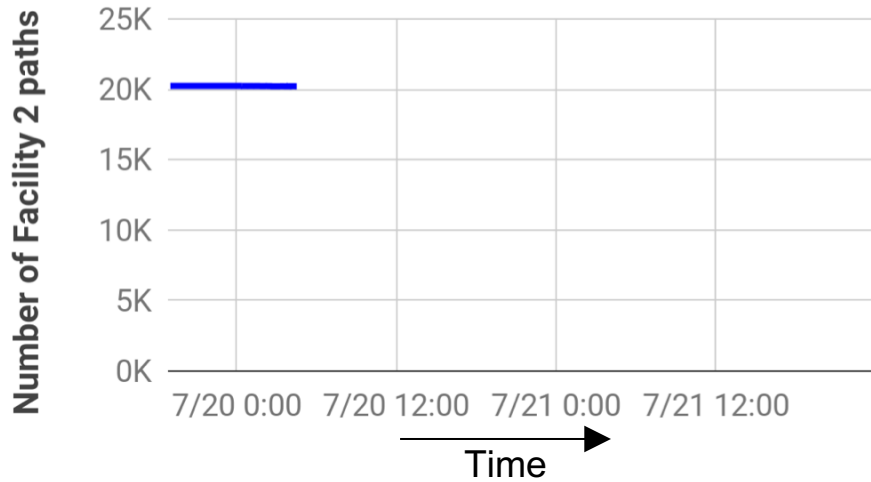

Track the BGP updates of the stable paths for changes in the communities values that indicate ingress point change.

Passive outage detection: **Monitoring**

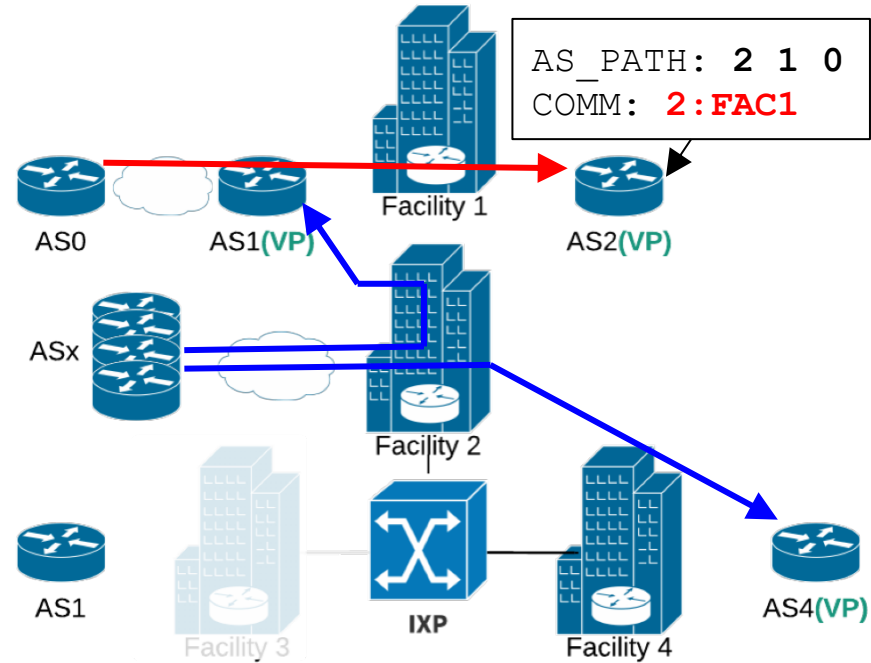
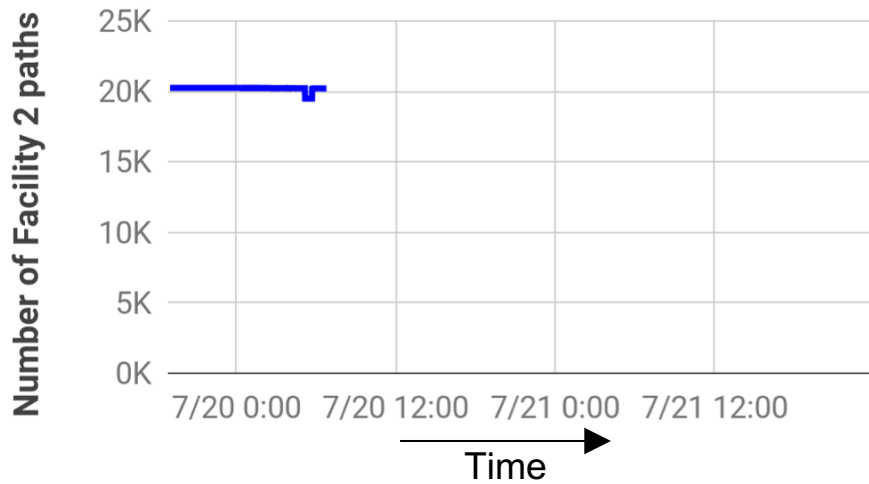

We don't care about AS-level path changes if the ingress-tagging communities remain the same.

Passive outage detection: **Outage signal**

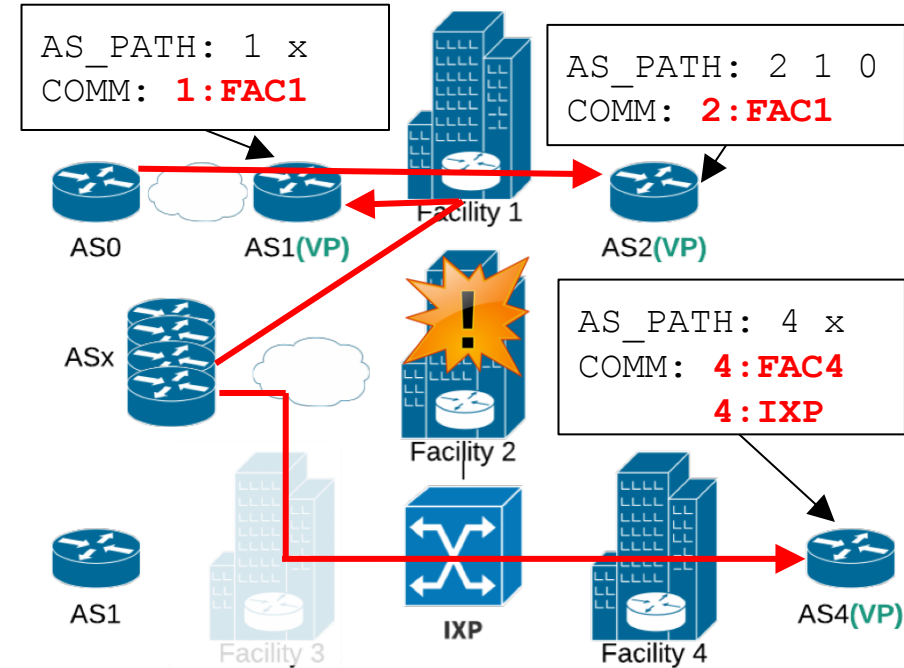
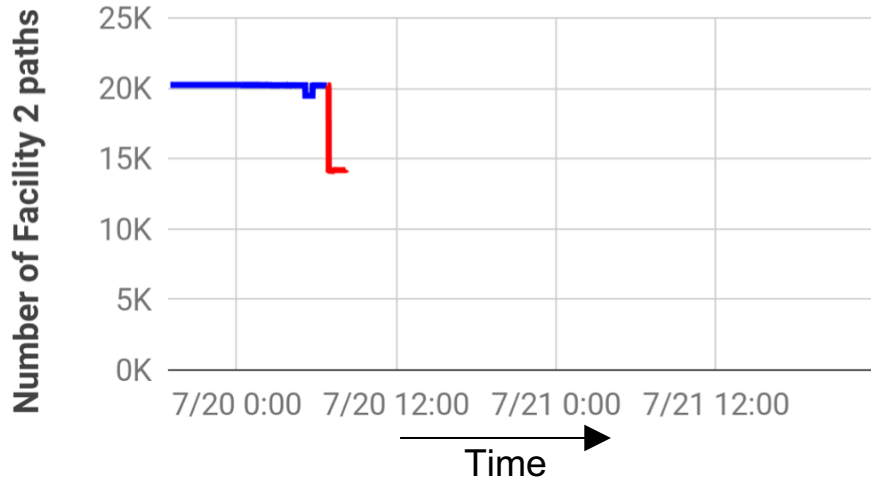

- Concurrent changes of communities values for the same facility.
- **Indication** of outage but not final inference yet!

Passive outage detection: **Outage signal**

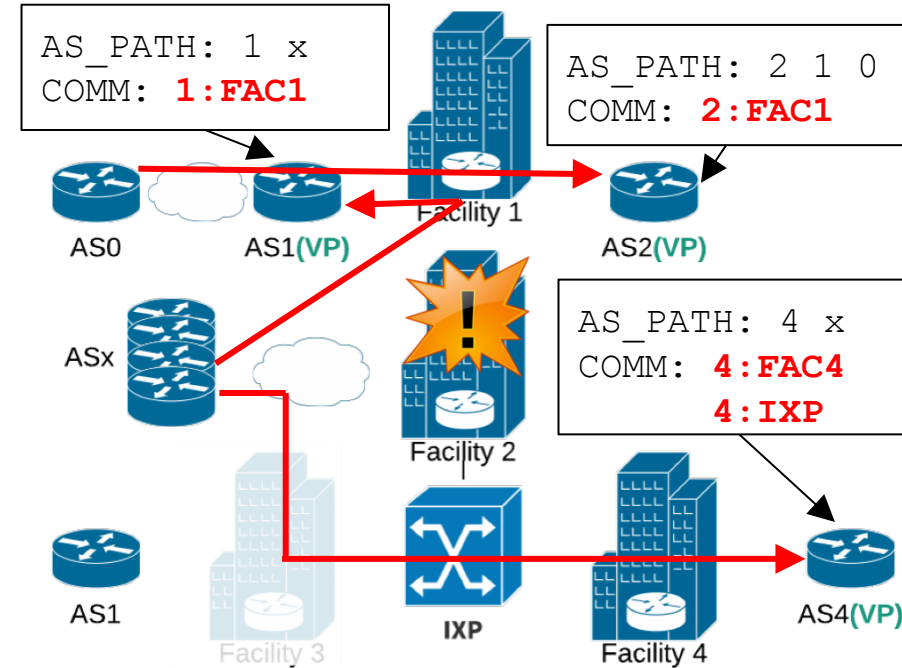
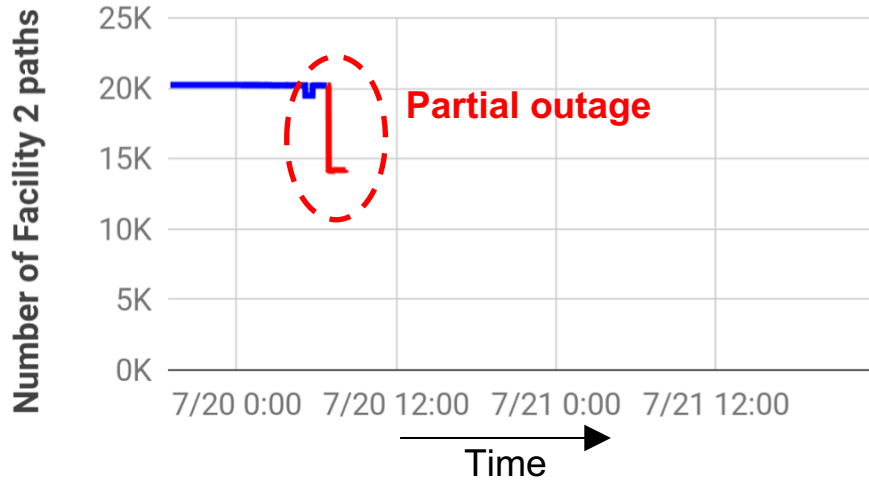

- Concurrent changes of communities values for the same facility.
- **Indication** of outage but not final inference yet!

Passive outage detection: **Outage signal**

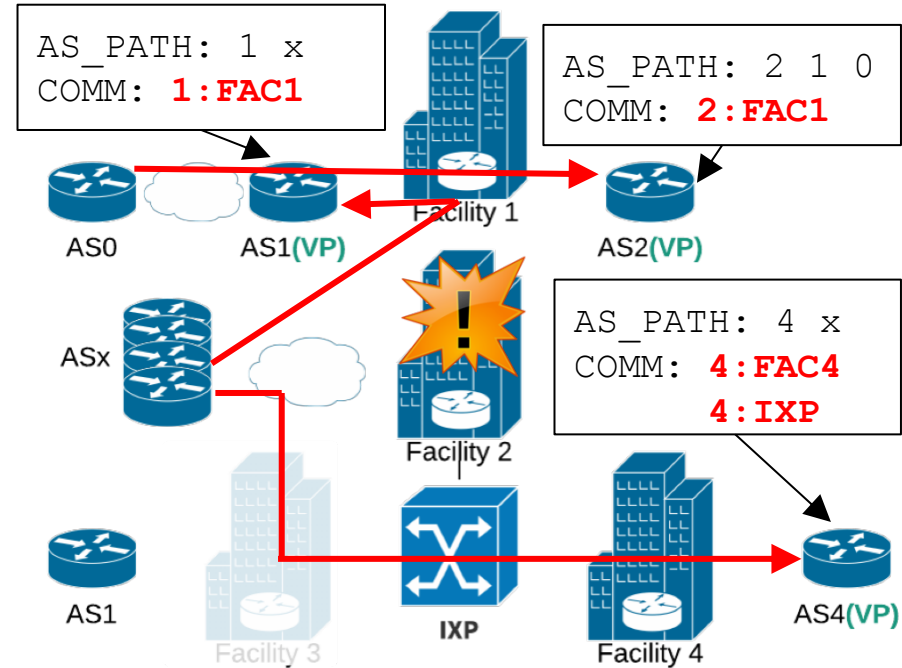
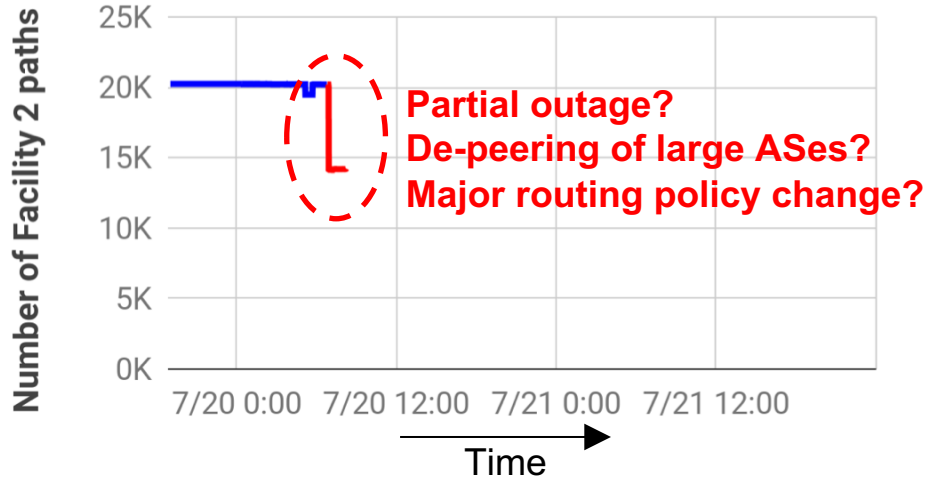

- Concurrent changes of communities values for the same facility.
- **Indication** of outage but not final inference yet!

Passive outage detection: **Outage signal**

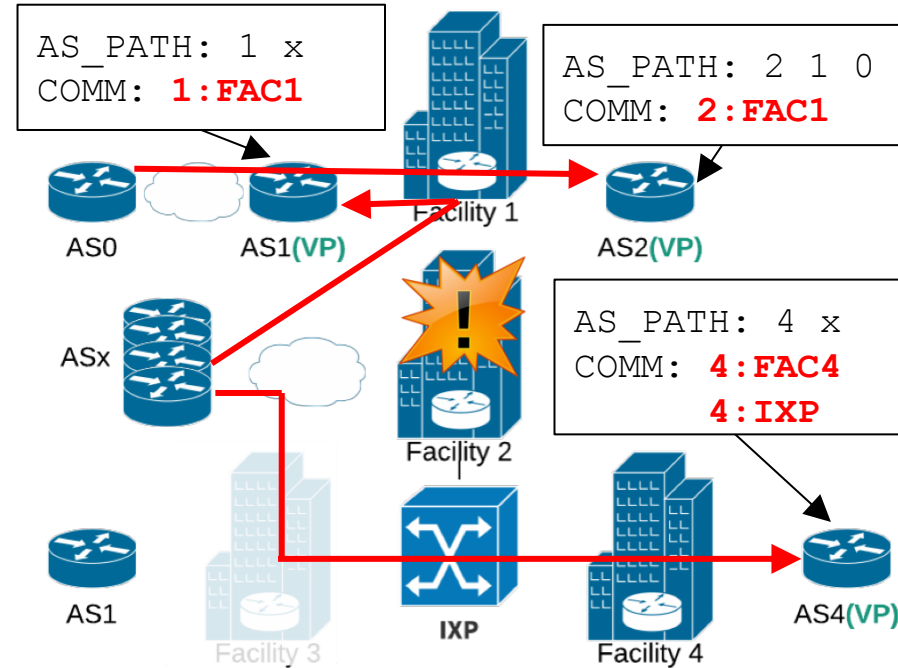
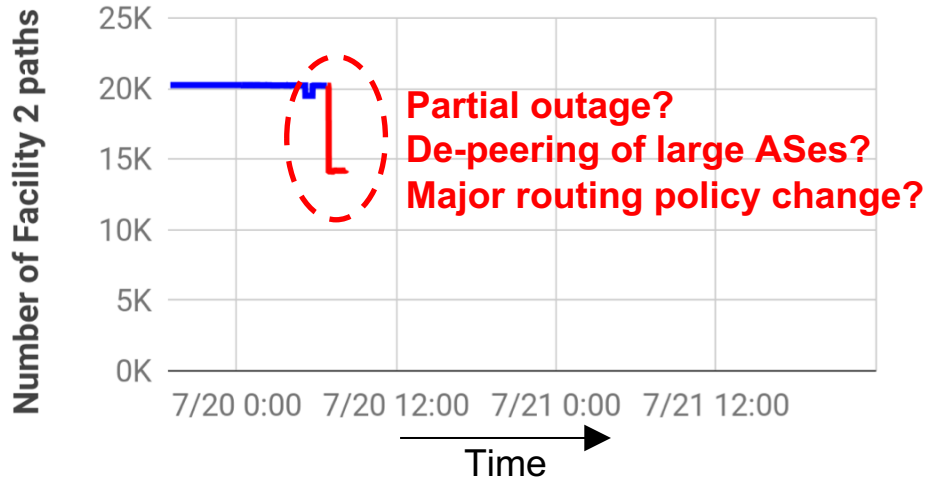

Signal investigation:

- Targeted active measurements.
- How disjoint are the affected paths?
- How many ASes and links have been affected?

Passive outage detection: **Outage tracking**

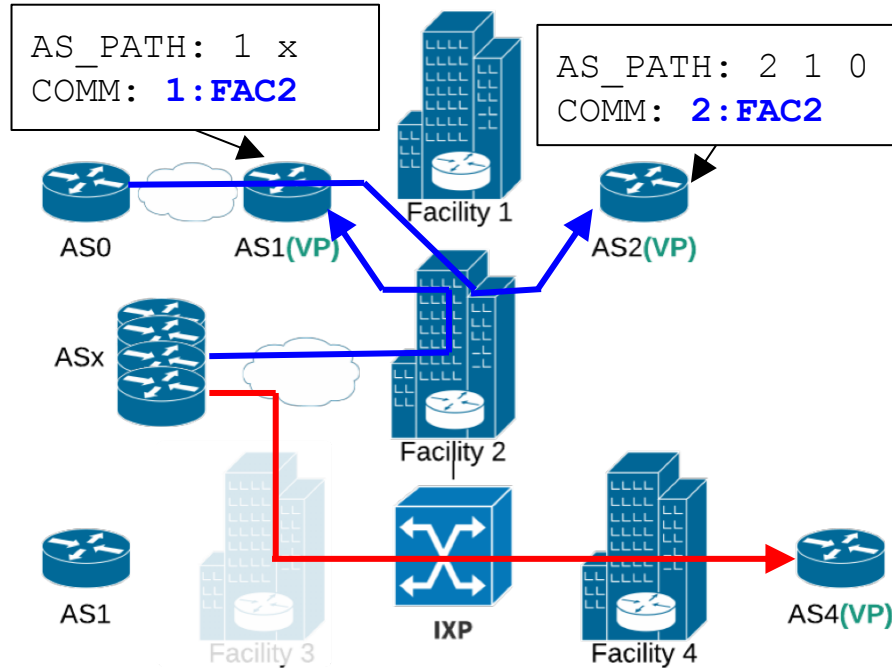
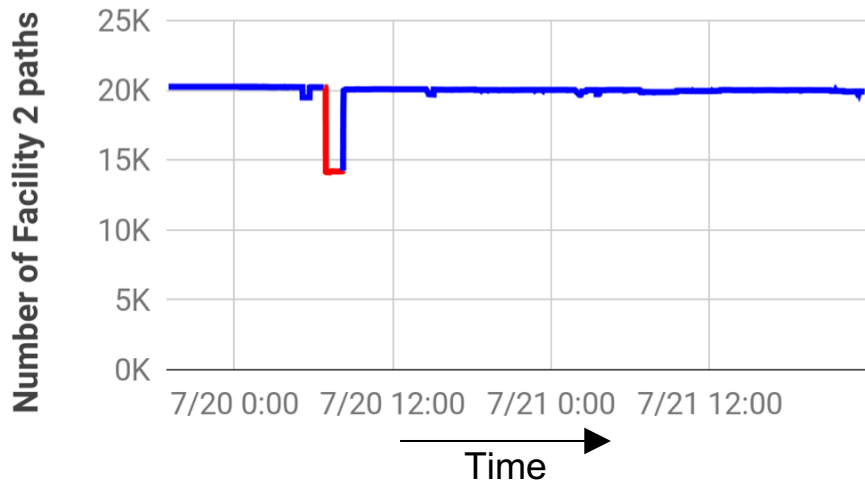

End of outage inferred when the majority of paths return to the original facility.

Outage localization is more complicated!

- The location of community values that trigger outage signals may not be the outage source!
- Communities encode the ingress point closest to our VPs (near-end infrastructure)
 - ASes may be interconnected over multiple intermediate infrastructures
 - Failures in intermediate infrastructures may affect the near-end infrastructure paths

Outage source disambiguation and localization

- Create **high-resolution co-location maps**:
 - AS to Facilities, AS to IXPs, IXPs to Facilities
 - Sources: PeeringDB, DataCenterMap, operator websites
- Decorrelate the behaviour of affected ASes based on their infrastructure colocation.

Outage source disambiguation and localization

Paths not investigated in aggregated manner, but at the granularity of separate (AS, Facility) co-locations.

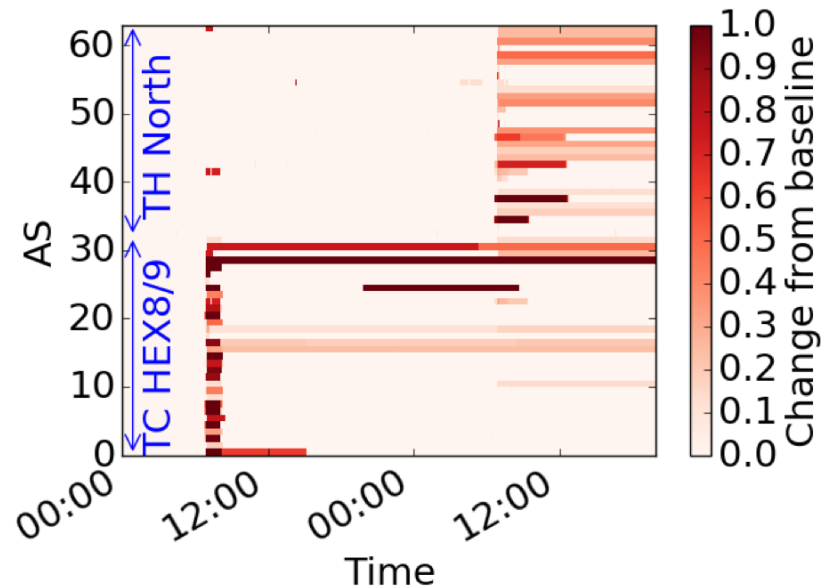
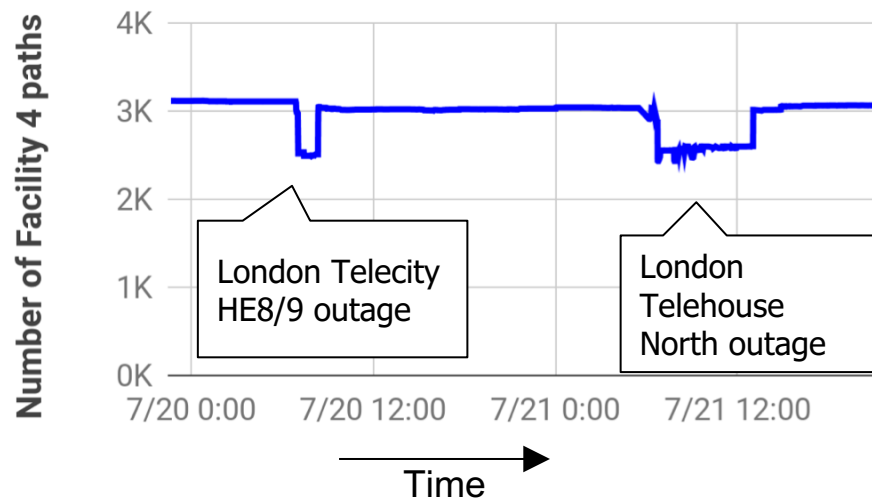

Outage source disambiguation and localization

Paths not investigated in aggregated manner, but at the granularity of separate (AS, Facility) co-locations.

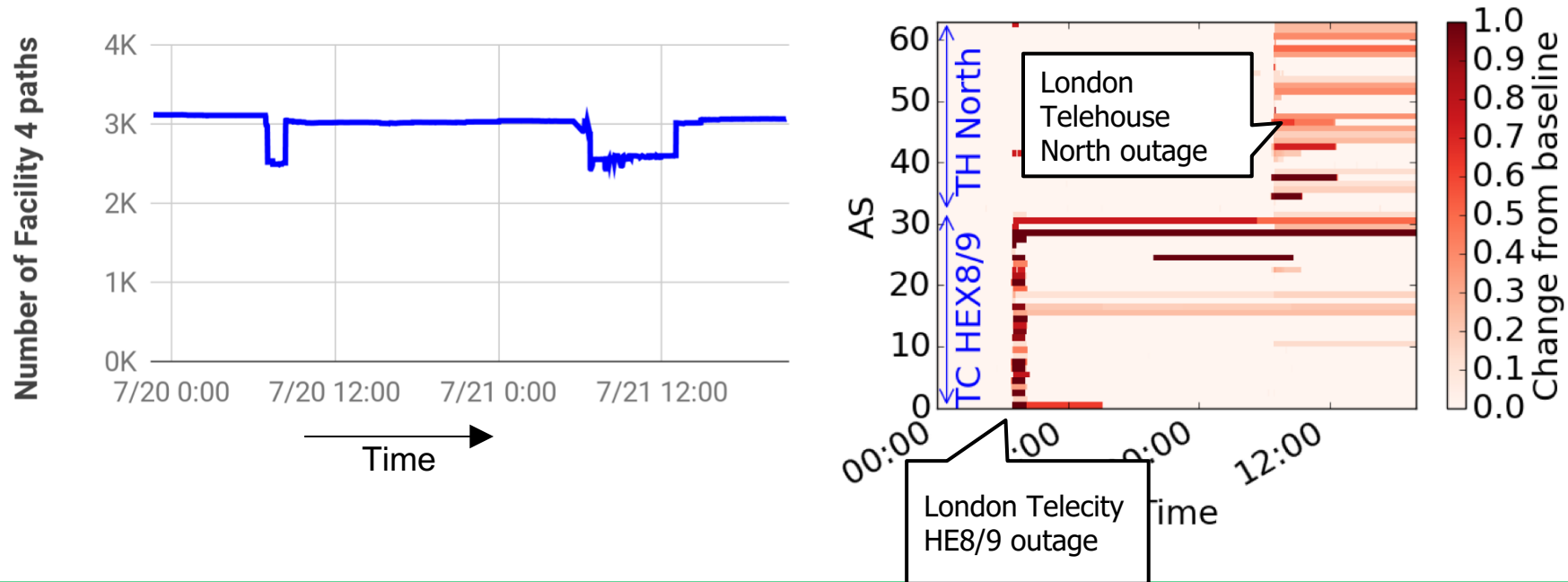

Detecting peering infrastructure outages

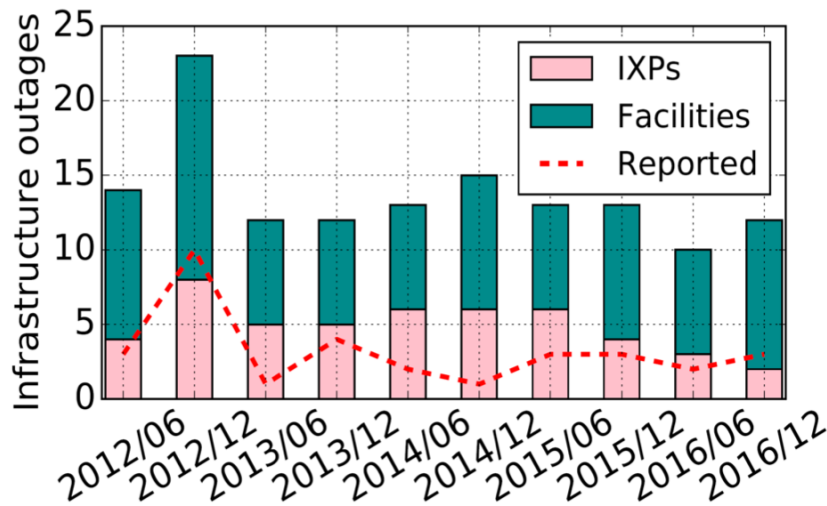

- **159** outages in 5 years of BGP data
 - **76%** of the outages not reported in popular mailing lists/websites
- Validation through status reports, direct feedback, social media
 - **90%** accuracy, **93%** precision (for trackable PoPs)

Effect of outages on Service Level Agreements

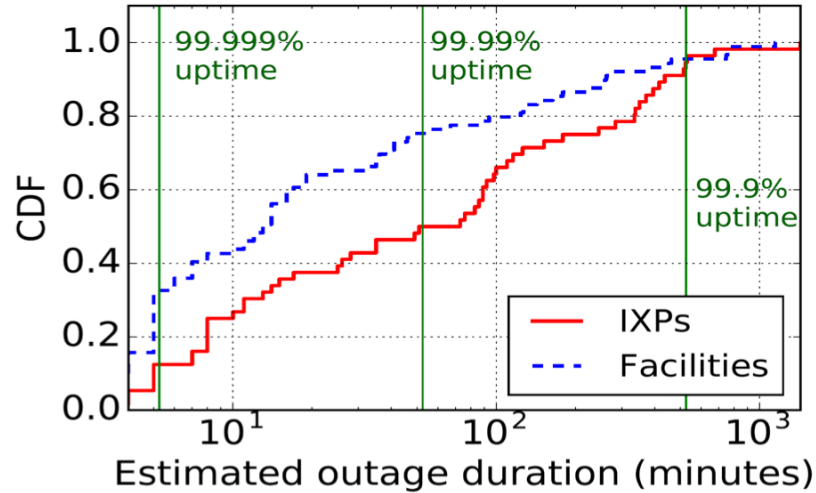

~**70%** of failed facilities below 99.999% uptime

~**50%** of failed IXPs below 99.99% uptime

5% of failed infrastructures below 99.9% uptime!

Measuring the impact of outages

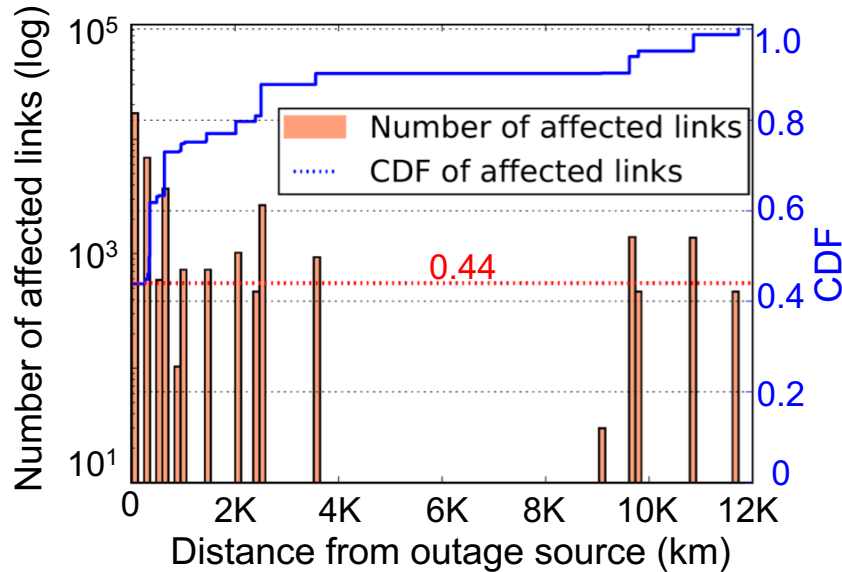

> **56 %** of the affected links in different country, > **20%** in different continent!

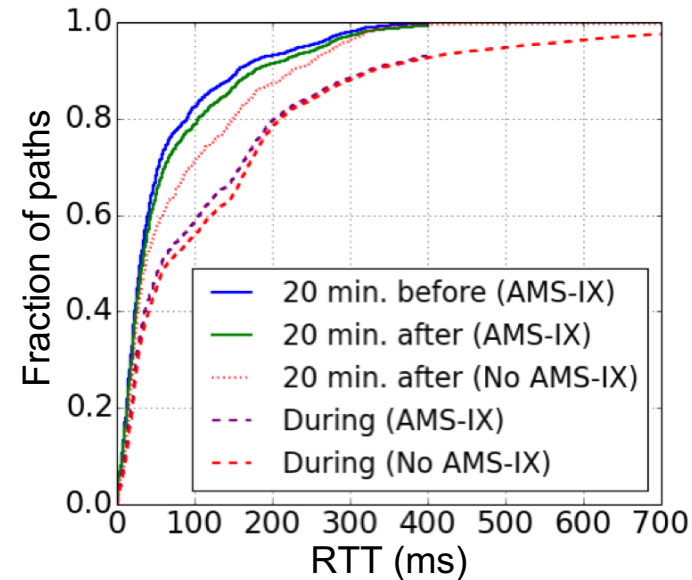

Fraction of routes with **RTT > 100** ms: **20%** before/after AMS-IX outage, **40%** during AMS-IX outage

Conclusions

- **Timely** and **accurate** infrastructure-level outage detection through **passive** BGP monitoring
- Majority of outages not (widely) reported
- Remote peering and infrastructure interdependencies **may cause problems in remote** locations that are hard to track
- **Hard evidence** on outages can improve accountability, transparency and resilience strategies

Questions / Comments?
